

TEKNOWARE SIGNAL WIRELESS BELL PUSH SYSTEM

USER MANUAL

Customer:

General

Project:

General

Date:

21.3.2023

Confidentiality:

Public

CONTENTS

1	GENERAL INFORMATION	2
1.1	Scope	2
1.1.1	Teknoware Signal receivers	2
1.1.2	Teknoware Signal push buttons	5
1.2	Handling	10
1.3	Cleaning	11
1.4	Storage conditions	11
2	FUNCTIONAL DESCRIPTION	12
2.1	Teknoware Signal push buttons	12
2.1.1	Version 1 and version 2 push buttons	12
2.2	Receiver with constant output (TSF0285)	12
2.3	Receiver with constant output (TSF0275)	13
2.4	Receiver with control output (TSF0286)	14
2.5	Receiver with control output (TSF0276)	15
3	INSTALLATION	17
3.1	Push buttons	17
3.2	Receivers	18
3.2.1	Wiring examples for receivers with constant output (TSF0285, TSF0275)	20
3.2.2	Wiring examples for receivers with control output (TSF0286, TSF0287, TSF0276)	21
4	PROGRAMMING	22
4.1	Resetting the receiver memory	25
5	DOCUMENT INFORMATION	26

1 GENERAL INFORMATION

1.1 Scope

The scope of this manual covers the receivers listed in chapter 1.1.1 and push buttons listed in chapter 1.1.2.

1.1.1 Teknoware Signal receivers

Table 1. Receivers 24 V TSF028x

Teknoware code	Description	
TSF0285	Receiver, 4 channels, 868.3 MHz, constant output	
TSF0286	Receiver, 4 channels, 868.3 MHz, signal output (duration 1 s)	
TSF0287	Receiver, 4 channels, 902.875 MHz (for North America), signal output (duration 1 s), FCC approved	similar to TSF0286

Table 2. Receivers 12 V TSF027x

Teknoware code	Description	
TSF0275	Receiver, 4 channels, 868.3 MHz, constant output	
TSF0276	Receiver, 4 channels, 868.3 MHz, signal output (duration 1 s)	

Table 3. Receiver technical data TSF028x

Technical data TSF028x	
Input voltage, current	18–32 V _~ ; 800 mA
Fuse	1 A fuse (integrated)
Nominal voltage	24 V
Receiver category	2
Frequency and modulation	868.3 MHz ASK for EU, Australia, Russia, and other countries outside North America. No known restrictions on putting into service in EU countries. 902.875 MHz FSK for North America.
Sensitivity (at 25 °C)	–96 dBm
Maximum load	200 mA / channel
Protection class	IP20
Weight	66 g
Ambient temperature range	–25 °C...+70 °C (operational) –40 °C...+70 °C (storage)
Operating range	up to 30 m
Connectors	spring clamp connectors, 0.5–1.5 mm ²
Wireless buttons TSF03XX	max 30 pcs / receiver

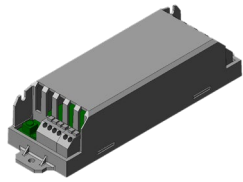
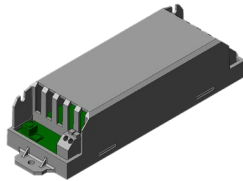
Table 4. Receiver technical data TSF027x

Technical data TSF027x	
Input voltage, current	9–15 V _~ ; 800 mA
Fuse	1 A fuse (integrated)
Nominal voltage	12 V _~
Receiver category	2
Frequency and modulation	868.3 MHz ASK for EU, Australia, Russia, and other countries outside North America. No known restrictions on putting into service in EU countries.

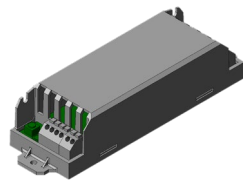
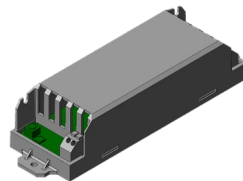
Technical data TSF027x	
Sensitivity (at 25 °C)	-96 dBm
Maximum load	200 mA / channel
Protection class	IP20
Weight	66 g
Ambient temperature range	-25 °C...+70 °C (operating) -40 °C...+70 °C (storage)
Operating range	up to 30 m
Connectors	spring clamp connectors, 0.5–1.5 mm ²
Wireless buttons TSF03XX	max 30 pcs / receiver

1.1.2 Teknoware Signal push buttons

Pole mounted buttons

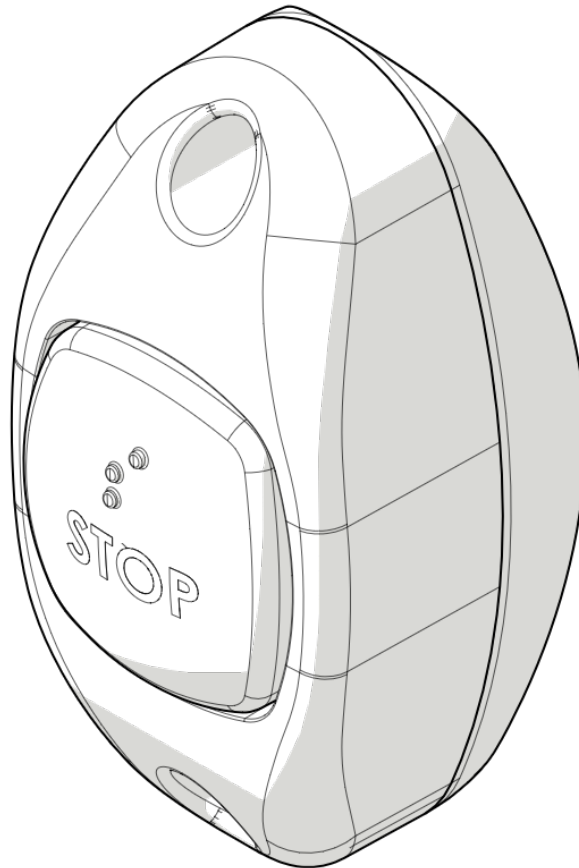



Table 5. Pole mounted button options

Button type		Grey body RAL7040	Yellow body RAL1023	Red body RAL3020
	Red (RAL3020) STOP button with braille	TSF0300	TSF0308	TSF0322
	Grey (RAL7040) STOP button with braille	on request	on request	TSF0320

Button type		Grey body RAL7040	Yellow body RAL1023	Red body RAL3020
	Blue (RAL5005) STOP button with braille	TSF0316	TSF0318	on request
	Blue (RAL5005) STOP button with braille for disabled	TSF0302	TSF0310	on request
	Blue (RAL5005) STOP button with braille for pram	TSF0304	TSF0312	on request
	Blue (RAL5005) STOP button with braille for senior citizens	TSF0306	TSF0314	on request
	Red (RAL3020) STOP button with braille, 902.875 MHz for North America	TSF0300U	on request	on request
	Blue (RAL5005) STOP button with braille for disabled, 902.875 MHz for North America	TSF0302U	on request	on request
	Blue (RAL5005) HALTE button with braille	TSF0330	TSF0331	on request
	Red (RAL3020) ALARM button with braille	on request	on request	on request

Vertical flat surface mounted buttons

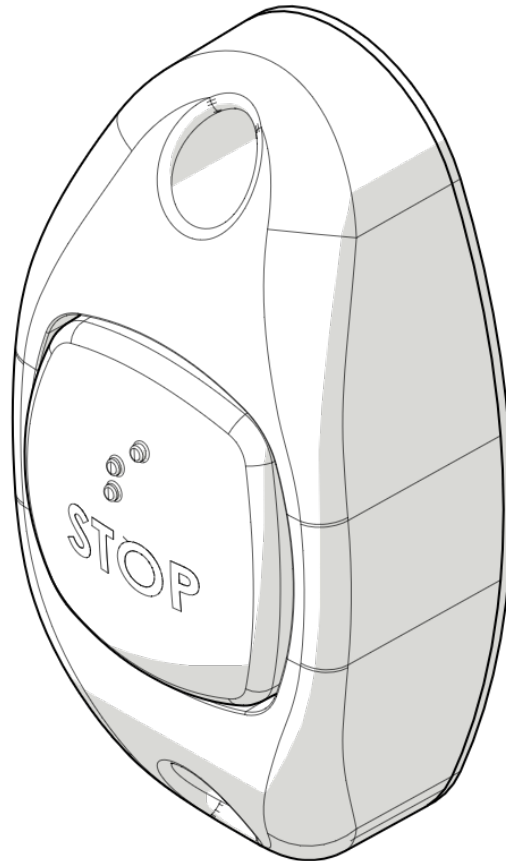





Table 6. Vertical flat surface mounted button options

Button type		Grey body RAL7040	Yellow body RAL1023	Red body RAL3020
	Red (RAL3020) STOP button with braille	TSF0301	TSF0309	TSF0323
	Grey (RAL7040) STOP button with braille	on request	on request	TSF0321
	Blue (RAL5005) STOP button with braille	TSF0317	TSF0319	on request

Button type		Grey body RAL7040	Yellow body RAL1023	Red body RAL3020
	Blue (RAL5005) STOP button with braille for disabled	TSF0303	TSF0311	on request
	Blue (RAL5005) STOP button with braille for pram	TSF0305	TSF0313	on request
	Blue (RAL5005) STOP button with braille for senior citizens	TSF0307	TSF0315	on request
	Red (RAL3020) STOP button with braille, 902.875 MHz for North America	on request	on request	on request
	Blue (RAL5005) STOP button with braille for disabled, 902.875 MHz for North America	on request	on request	on request
	Blue (RAL5005) HALTE button with braille	TSF0328	TSF0329	on request
	Red (RAL3020) ALARM button with braille	on request	on request	TSF0327

Horizontal flat surface mounted buttons

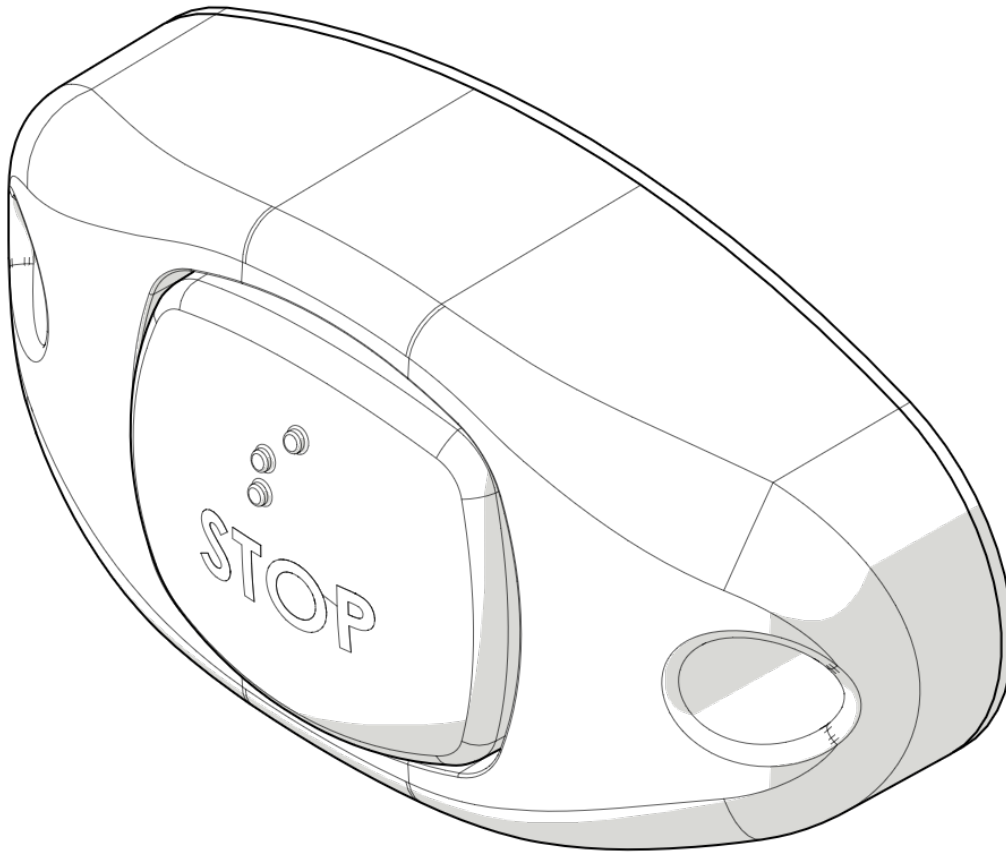

Table 7. Horizontal flat surface mounted buttons



Button type		Grey body RAL7040	Yellow body RAL1023	Red body RAL3020
	Red (RAL3020) STOP button with braille	TSF0324	TSF0326	on request
	Blue (RAL5005) STOP button with braille	on request	TSF0325	on request
Other options are available on request.				

Table 8. Teknoware Signal push button technical data

Technical data	
Output signal	32-bit RF signal
Frequency and modulation	868.3 MHz ASK for EU, Australia, Russia, and other countries outside North America. No known restrictions on putting into service in EU countries. 902.875 MHz for North America.
Power requirement	+5 dBm (3.2 mW)
Weight	37 g (flat surface mounting, vertical and horizontal) 43 g (pole mounting)
Ambient temperature range	-25 °C...+70 °C (operational) -40 °C...+70 °C (storage)
Operating range	up to 30 m
Installation	with screws through holes Ø 5 mm, max. torque 3 Nm
Pole diameter (pole mounted buttons)	32–36 mm
Colours, body	Grey RAL7040 Yellow RAL1023 Red RAL3020
Colours, button	Red RAL3020 with white text “STOP” or “ALARM” Grey RAL7040 with black text “STOP” Blue RAL5005 with white text “STOP” or “HALTE” Blue RAL5005 with white symbol and braille

1.2 Handling

These units contain electronic components. Always handle them with care and avoid inducing any sort of unnecessary mechanical stress or contaminating the units with grease or other chemicals.

1.3 Cleaning

Suitable cleaning agents

The visible surfaces can be cleaned with a mild, neutral detergent. Cleaning agents that are declared suitable for plastics and do not fall into any of the categories listed below in the forbidden substances can be used.

Cleaning agents that are absolutely forbidden

- Cleaners with solvents, thinners, acetone or chlorinated hydrocarbons
- Acids
- Lyes
- Strongly alkaline cleaners
- Abrasive cleaners or abrasive aids.

1.4 Storage conditions

- The units shall not be taken out of the packaging in which they are delivered, nor shall the packaging be altered in a manner which might impair its ability to protect the units from the surrounding environment.
- The units shall be stored in a dry, dust-free environment protected from direct sunlight, rain and other severe weather conditions.
- The ambient temperature must be within the temperature range of $-40\text{ }^{\circ}\text{C}\dots+70\text{ }^{\circ}\text{C}$ ($-40\text{ }^{\circ}\text{F}\dots+158\text{ }^{\circ}\text{F}$) at all times, and the storage area needs to be climate controlled.

Failure to comply with the requirements might result in the warranty becoming void.

2 FUNCTIONAL DESCRIPTION

2.1 Teknoware Signal push buttons

Teknoware Signal has built-in energy harvesters, which convert the linear motion of pushing the button into energy. Therefore, the buttons do not have a traditional power source of any kind.

With the harvested energy, the buttons are capable of sending an RF signal that includes a 32-bit ID for the button. 32 bits result in billions of possibilities that make it highly improbable to have buttons with the same ID. Due to this feature, the buttons can be programmed for separate channels.

Multiple buttons can be programmed for one channel and one button can be programmed for multiple channels.

2.1.1 Version 1 and version 2 push buttons

The programming of the buttons varies slightly depending on the product version: product version 1 buttons have a TEACH mode for programming, while version 2 buttons do not require a separate TEACH mode. The product version is marked on the button's type label, see Figure 1.

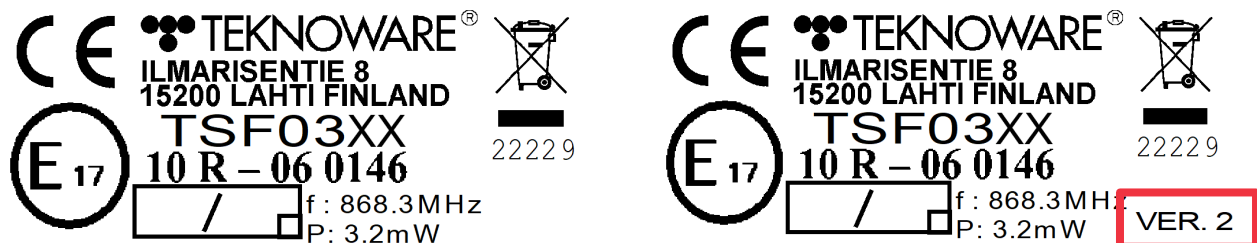

Figure 1. Type labels for version 1 (left) and version 2 (right) buttons: note the VER. 2 mark on the lower right

2.2 Receiver with constant output (TSF0285)

A maximum of 30 buttons can be programmed for one receiver. The receiver has four channels for which the buttons can be programmed. Every channel has an output of 24 VDC, and the maximum current per channel is 200 mA.

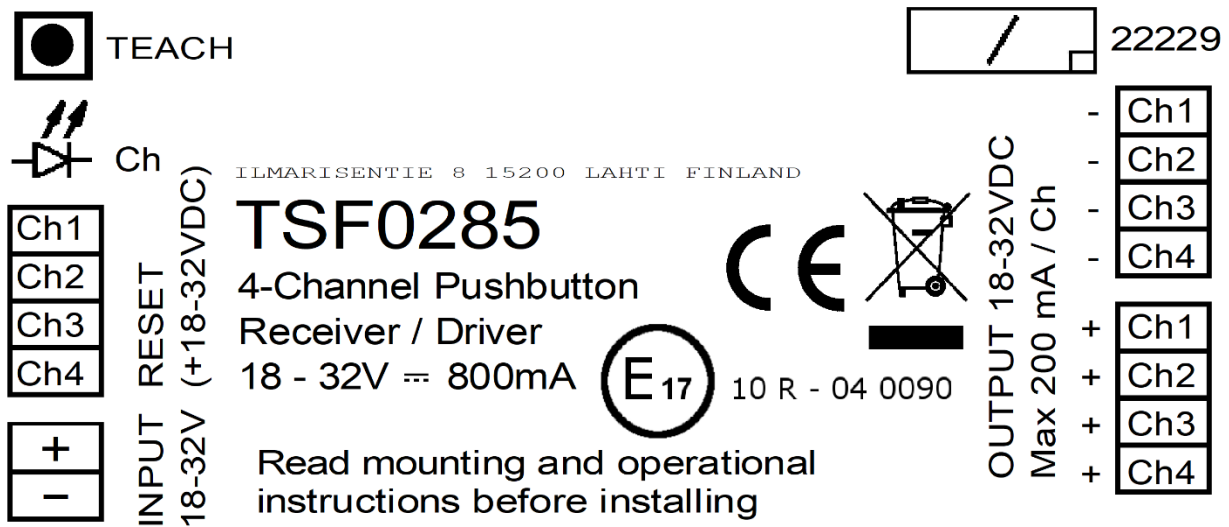

Figure 2. Type label for TSF0285

Inputs include a supply voltage of 24 VDC and a 24 VDC reset signal for each channel. Reset inputs turn off the output of the channel in question (for example, a door opens and sends a signal that turns off a stop sign).



NOTE!

Once a button is pressed, TSF0285 receiver will switch the output on. To switch it off, it requires a 24 VDC reset input signal.

2.3 Receiver with constant output (TSF0275)

A maximum of 30 buttons can be programmed for one receiver. The receiver has four channels for which the buttons can be programmed. Every channel has an output of 12 VDC, and the maximum current per channel is 200 mA.

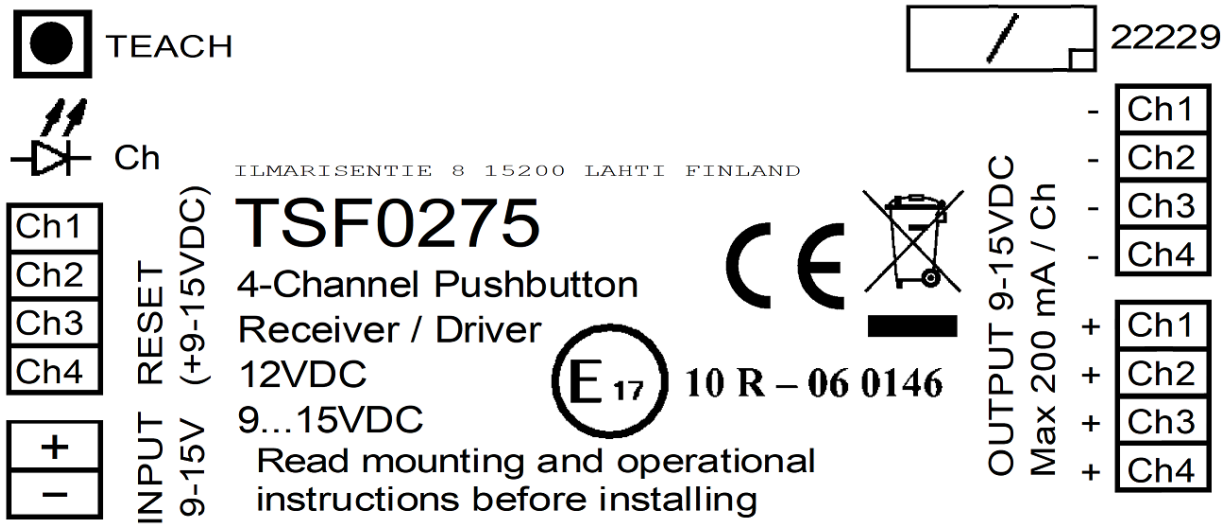

Figure 3. Type label for TSF0275

Inputs include a supply voltage of 12 VDC and a 12 VDC reset signal for each channel. Reset inputs turn off the output of the channel in question (for example, a door opens and sends a signal that turns off a stop sign).



NOTE!

Once a button is pressed, TSF0275 receiver will switch the output on. To switch it off, it requires a 12 VDC reset input signal.

2.4 Receiver with control output (TSF0286)

A maximum of 30 buttons can be programmed for one receiver. The receiver has four channels for which the buttons can be programmed.

Inputs include supply voltage of 24 VDC. Every channel has an output of 24 VDC, and the maximum current per channel is 200 mA.

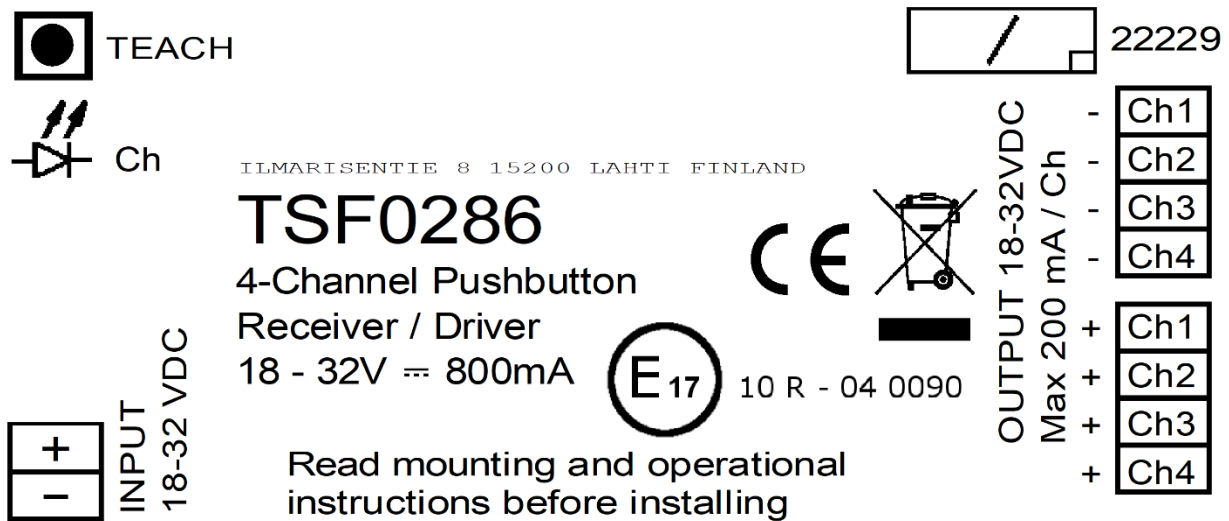

Figure 4. Type label for TSF0286



NOTE!

Once a button is pressed, TSF0286 receiver will switch the output on for only one second. Therefore, it does not require reset input signals.

2.5 Receiver with control output (TSF0276)

A maximum of 30 buttons can be programmed for one receiver. The receiver has four channels for which the buttons can be programmed.

Inputs include supply voltage of 12 VDC. Every channel has an output of 12 VDC, and the maximum current per channel is 200 mA.

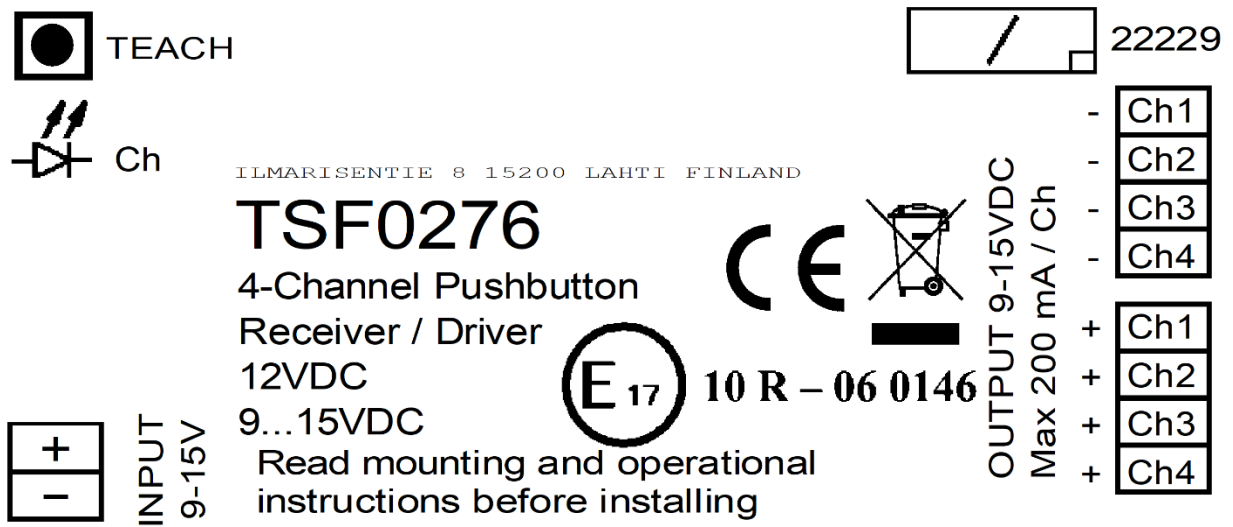

Figure 5. Type label for TSF0276



NOTE!

Once a button is pressed, TSF0276 receiver will switch the output on for only one second. Therefore, it does not require reset input signals.

3 INSTALLATION

3.1 Push buttons



NOTE!

Product version 1 buttons must be programmed before installation. See chapter 4 for programming instructions.

See Figure 6 and Figure 7 for dimensions for the pole mounted and flat surface buttons. The buttons are mounted with screws through the Ø 5 mm holes. The maximum torque for the screws is 3 Nm for both pole mounted and flat surface buttons. No wiring is required!

Do not use countersunk screws when installing the stop buttons as they can damage the stop button body. Teknoware recommends the following types of screws to be used in installation:

- Pole mounted buttons: Teknoware code QL42130C (PLATE SCREW PAN TX20 4.2x13mm ZN DIN 7981F)
- Flat surface buttons: Teknoware code OW319 (MACHINE SCREW PAN TX20 M4x12mm A2-70 ISO 14583)

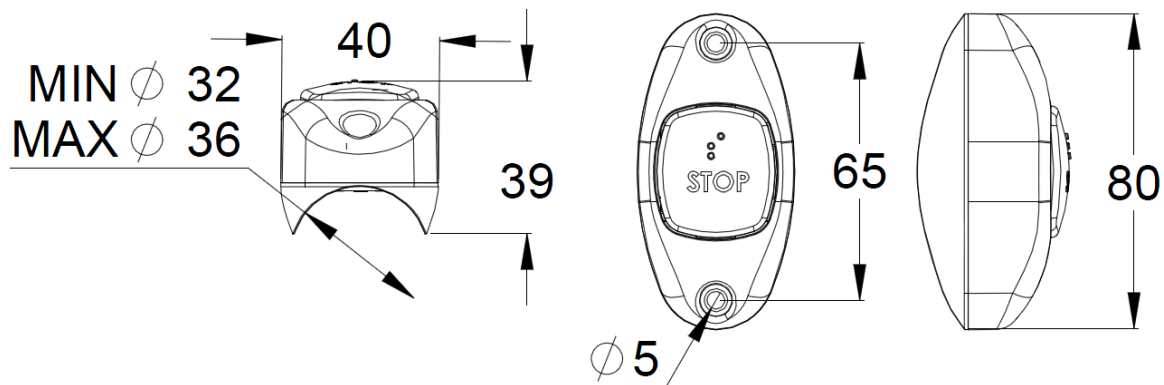

Figure 6. Dimensions of a button for pole mounting

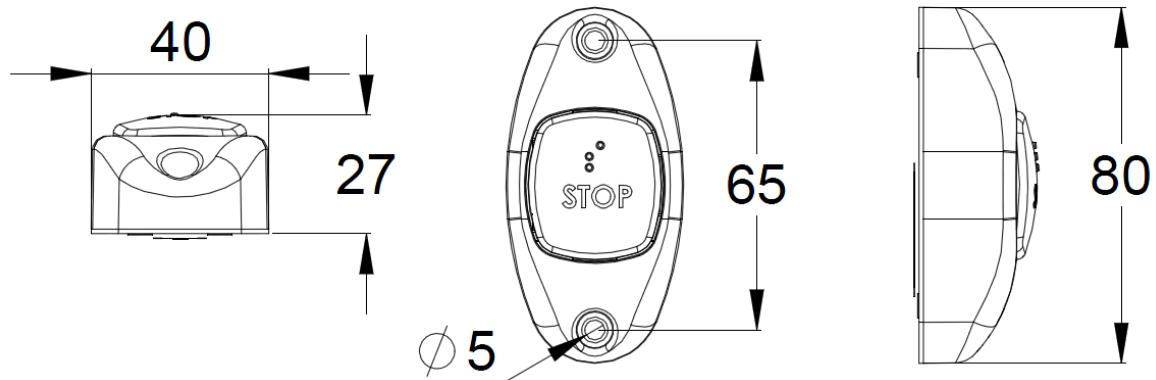

Figure 7. Dimensions of a button for flat surfaces

3.2 Receivers



NOTE!

Do not mount the receiver in a location that blocks the RF signals from the buttons.

See Figure 8 for the dimensions of the receivers. The receiver can be mounted with screws through the holes provided on two edges of the unit. See chapters 3.2.1 and 3.2.2 for wiring examples for each type of receiver.

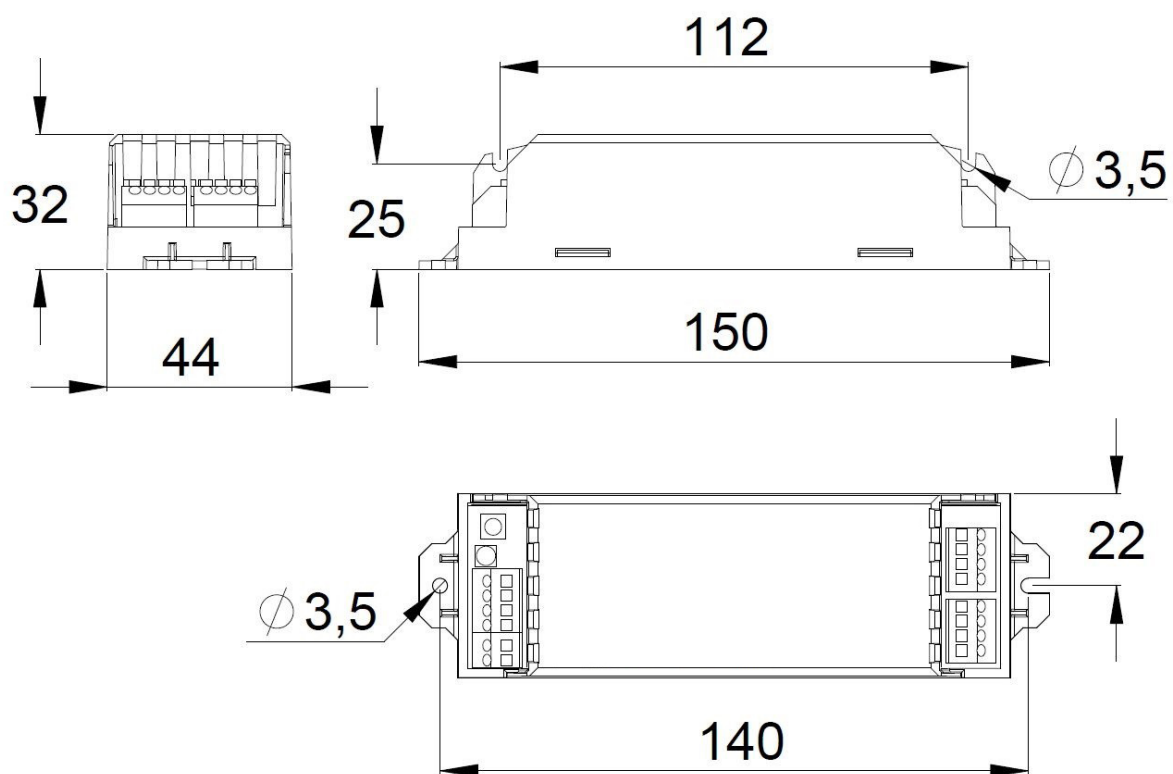

Figure 8. Dimensions of the receivers

3.2.1 Wiring examples for receivers with constant output (TSF0285, TSF0275)

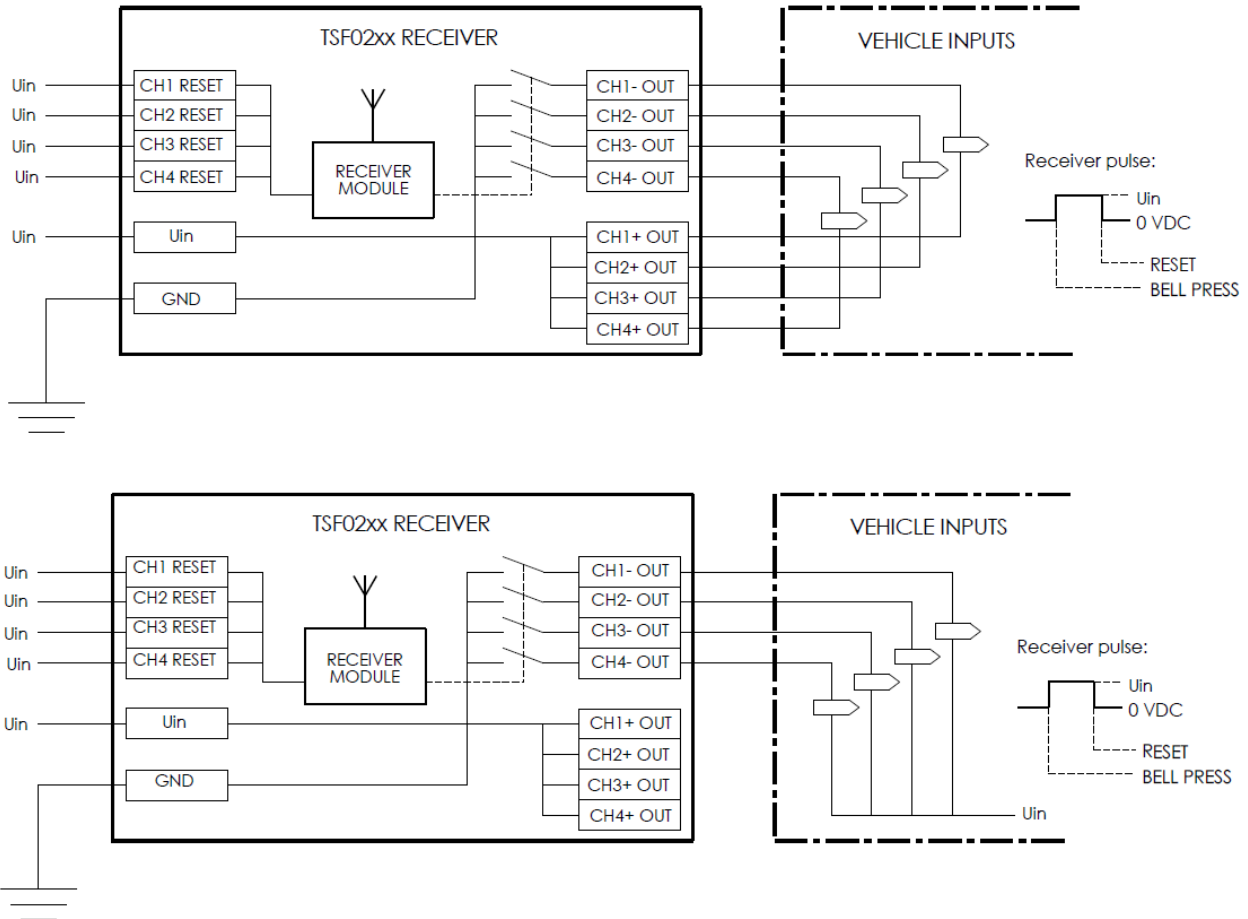

Figure 9. Two wiring alternatives for receivers with constant output

3.2.2 Wiring examples for receivers with control output (TSF0286, TSF0287, TSF0276)

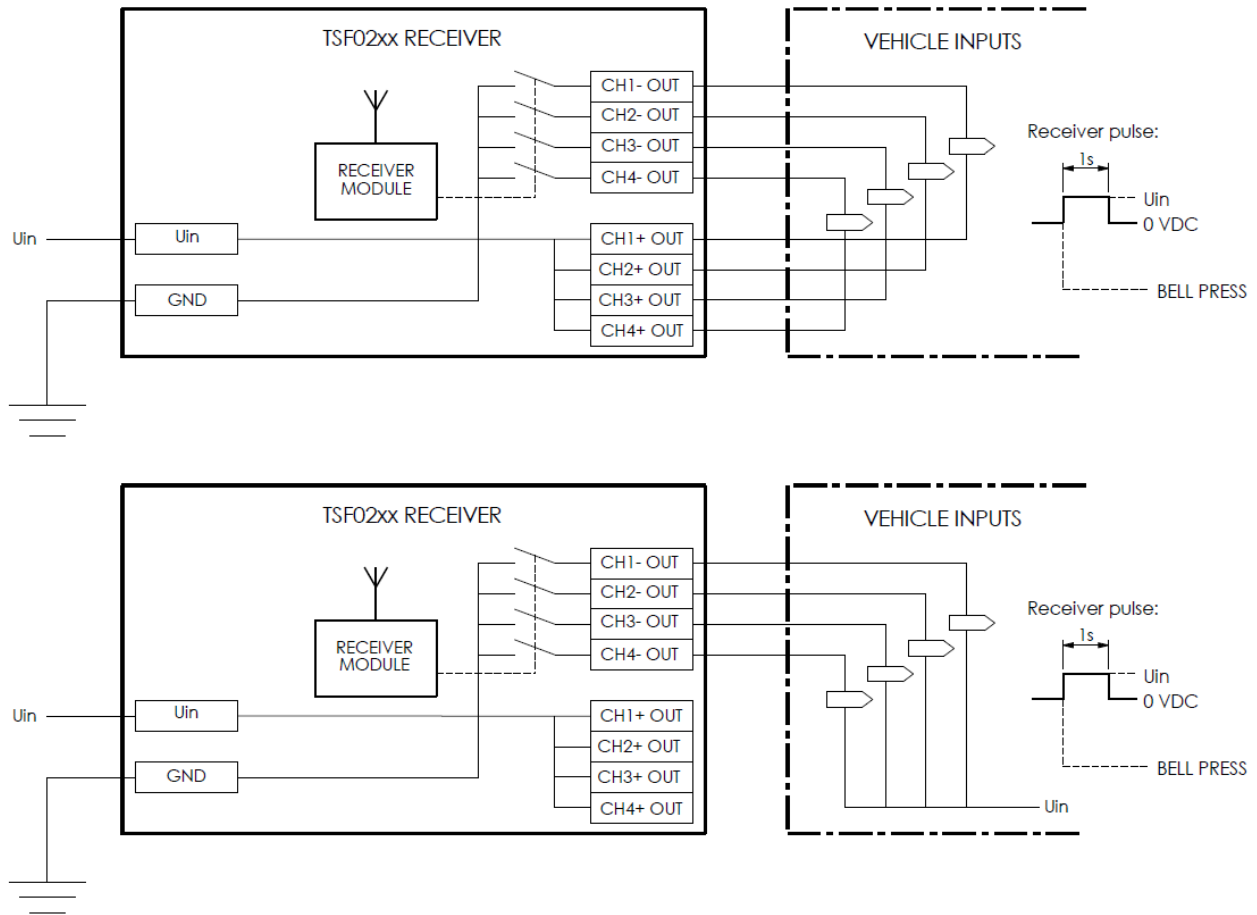

Figure 10. Two wiring alternatives for receivers with control output

4 PROGRAMMING

Before beginning the programming, check the push button's product version, see Figure 1 in chapter 2.1.



NOTE!

To avoid accidental programming, do not program multiple receivers simultaneously within the range of the RF signals.

NOTE!

The channels can be programmed in any order while the corresponding LED is flashing.



Channel 1 = BLUE

Channel 2 = GREEN

Channel 3 = RED

Channel 4 = PURPLE

1. Connect a 24 VDC or 12 VDC supply voltage to the receiver. See chapter 3.2.1 for wiring examples for receivers with constant output and chapter 3.2.2 for wiring examples for receivers with control output.
2. If programming version 1 buttons, set the buttons to TEACH mode (see Figure 11).

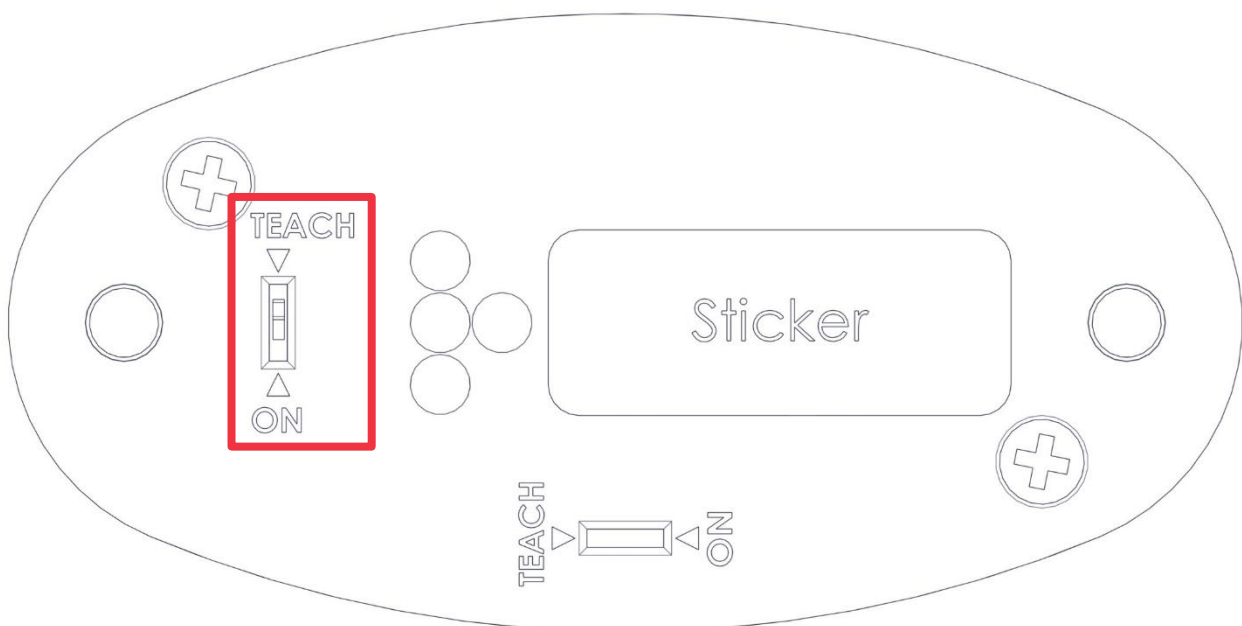

Figure 11. ON / TEACH switch located behind product version 1 buttons

3. Programming for Channel 1:
 - a. Press the TEACH button on the receiver for approximately 0.5 seconds so that the LED starts flashing blue.
 - b. Press every button designated for channel 1 while the LED is lit. Pressing a button for a second time, while the LED is lit, undoes the programming.
 - c. Mark the programmed buttons with their channel. If programming version 1 buttons, set them to ON mode (see Figure 11).
4. Programming for Channel 2:
 - a. Press the TEACH button on the receiver for approximately 0.5 seconds so that the LED starts flashing green.
 - b. Press every button designated for channel 2 while the LED is lit. Pressing a button for a second time, while the LED is lit, undoes the programming.
 - c. Mark the programmed buttons with their channel. If programming version 1 buttons, set them to ON mode (see Figure 11).
5. Programming for Channel 3:
 - a. Press the TEACH button on the receiver for approximately 0.5 seconds so that the LED starts flashing red.
 - b. Press every button designated for channel 3 while the LED is lit. Pressing a button for a second time, while the LED is lit, undoes the programming.
 - c. Mark the programmed buttons with their channel. If programming version 1 buttons, set them to ON mode (see Figure 11).
6. Programming for Channel 4:
 - a. Press the TEACH button on the receiver for approximately 0.5 seconds so that the LED starts flashing purple.
 - b. Press every button designated for channel 4 while the LED is lit. Pressing a button for a second time, while the LED is lit, undoes the programming.
 - c. Mark the programmed buttons with their channel. If programming version 1 buttons, set them to ON mode (see Figure 11).
7. Press the TEACH button on the receiver once more so that the LED stops flashing. The programming is now complete.
8. The memory of the receiver can be reset by pressing the reset button on the circuit board, inside the casing (see Figure 12 and Figure 13), for longer than 0.5 seconds.

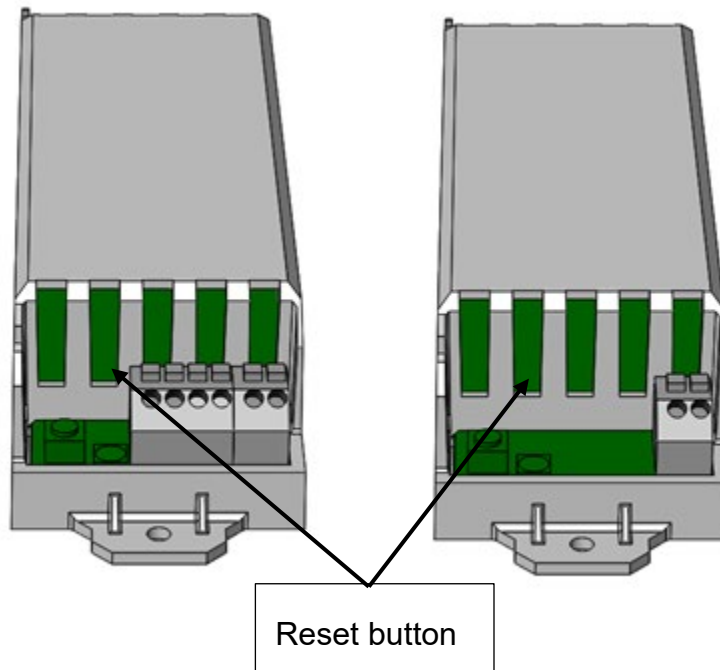

Figure 12. Location of the reset button. Left figure: TSF02075 & TSF0285. Right figure: TSF02076 & TSF0286.

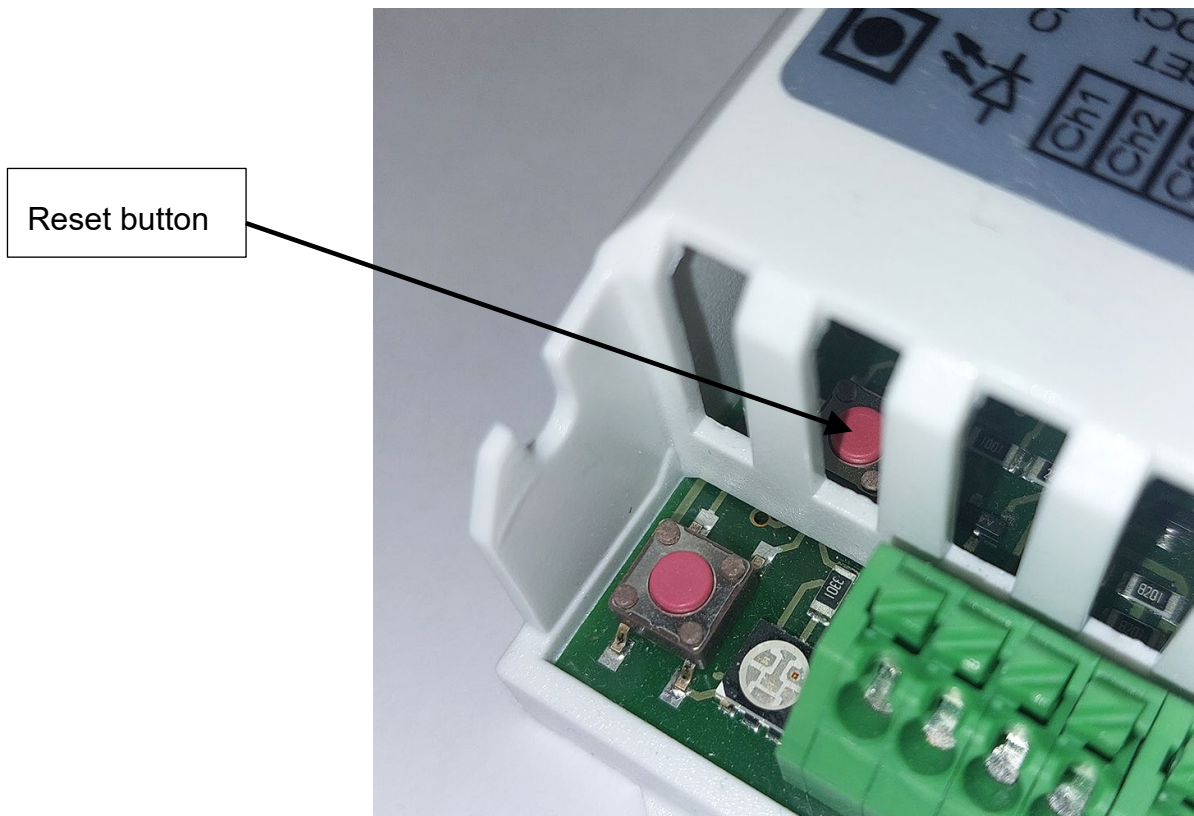

Figure 13. Close-up of the reset button inside the casing

4.1 Resetting the receiver memory

A maximum of 30 buttons can be programmed for one receiver. If buttons have been uninstalled and replaced without resetting the receiver memory, the memory slots of the system's receiver may be full. In that case, programming new buttons for the receiver is not possible.

The memory of the receiver can be reset by pressing the reset button on the circuit board, inside the casing (see Figure 12 and Figure 13), for longer than 0.5 seconds.

**NOTE!**

Remember to reprogram all the buttons in the system after resetting the receiver memory!

5 DOCUMENT INFORMATION

Project: General	Customer: General	Customer document reference: -
Prepared by: Inkeri Hyvönen	Checked by: Sonja Kuusanmaa	Approved by: Antti Koskelainen
Revision: 5	Pages: 26	Date: 21.3.2023

Revision follow-up

Revision:	Purpose:	Date:	Author:
0	Completely renewed document to new template	11.8.2020	Ella Hasa
1	Updated programming instructions for product versions 1 and 2.	4.2.2021	Inkeri Hyvönen
2	Added information about cleaning (ch. 1.3) and max. torque for stop buttons (ch. 4.1).	15.3.2021	Inkeri Hyvönen
3	Corrected information about TSF0287 in ch. 1.1.1.	24.5.2021	Inkeri Hyvönen
4	Updated product codes in chapter 1.1.2 and type labels in chapter 2, added chapters 3.2.1 and 3.2.2, changed document title.	19.8.2022	Inkeri Hyvönen
5	Added chapter 4.1.	21.3.2023	Inkeri Hyvönen



Teknoware Oy

Ilmarisentie 8, FI-15200 Lahti, Finland

Tel: +358 883 020

teknoware.com

documentation@teknoware.com

EC DECLARATION OF CONFORMITY

No. 635

The undersigned, representing the following manufacturer

Teknoware Oy
Ilmarisentie 8, FI-15200 Lahti, Finland

herewith declares that the product

Teknoware Signal wireless push button with one of the following product numbers:
TSF029x, TSF029xB, TSF03xx

is in conformity with the provisions of the following EC directive(s)

- | | |
|------------|---|
| 2014/53/EU | Directive 2014/53/EU of the European Parliament and of the Council of 16 April 2014 on the harmonisation of the laws of the Member States relating to the making available on the market of radio equipment and repealing Directive 1999/5/EC |
| 2012/19/EU | Directive 2012/19/EU of the European Parliament and of the Council of 4 July 2012 on waste electrical and electronic equipment (WEEE) |
| 2011/65/EU | Directive 2011/65/EU of the European Parliament and of the Council of 8 June 2011 on the restriction of the use of certain hazardous substances in electrical and electronic equipment |

and that the standards references below have been applied.

Place: Lahti, Finland

Date:

Signature:



Kai Kauto
Managing Director, Teknoware Oy

Digitally signed by
Teknoware VPN2
Date: 2022.08.08
12:54:40 +03'00'

References of harmonized standards applied for this EC declaration of conformity:

- | | |
|----------------------|---|
| EN 301 489-1: V2.2.0 | Electromagnetic compatibility and Radio spectrum Matters (ERM); |
| EN 301 489-3: V2.1.1 | Part 3: Specific conditions for Short-Range Devices (SRD) operating on frequencies between 9 kHz and 246 GHz |
| EN 61000-4-2:2009 | Electromagnetic compatibility (EMC); Part 4-2: Testing and measurement techniques – Electrostatic discharge immunity test; |
| EN 61000-4-3:2006 | Part 4-3: Testing and measurement techniques – Radiated, radio-frequency, electromagnetic field immunity test |
| +A1:2008+A2:2010 | |
| EN 300 220-2: V3.1.1 | Short Range Devices (SRD) operating in the frequency range 25 MHz to 1 000 MHz; Part 2: Harmonised Standard covering the essential requirements of article 3.2 of the Directive 2014/53/EU for non-specific radio equipment |
| EN 62479:2010 | Assessment of the compliance of low power electronic and electrical equipment with the basic restrictions related to human exposure to electromagnetic fields (10 MHz to 300 GHz) |
| EN 62368-1:2014 | Audio/video, information and communication technology equipment – Part 1: Safety requirements |

EC DECLARATION OF CONFORMITY

No. 639

The undersigned, representing the following manufacturer

Teknoware Oy
Ilmarisentie 8, FI-15200 Lahti, Finland

herewith declares that the product

Teknoware Signal receiver for wireless push buttons with one of the following product numbers:
TSF0285, TSF0286, TSF0275, TSF0276

is in conformity with the provisions of the following EC directive(s)

- 2014/53/EU Directive 2014/53/EU of the European Parliament and of the Council of 16 April 2014 on the harmonisation of the laws of the Member States relating to the making available on the market of radio equipment and repealing Directive 1999/5/EC
- 2012/19/EU Directive 2012/19/EU of the European Parliament and of the Council of 4 July 2012 on waste electrical and electronic equipment (WEEE)
- 2011/65/EU Directive 2011/65/EU of the European Parliament and of the Council of 8 June 2011 on the restriction of the use of certain hazardous substances in electrical and electronic equipment

and that the standards references below have been applied.

Place: Lahti, Finland

Date:

Signature:



Kai Kauto
Managing Director, Teknoware Oy

Digitally signed by
Teknoware VPN2
Date: 2022.08.08
12:53:41 +03'00'

References of harmonized standards applied for this EC declaration of conformity:

- EN 301 489-3: V2.1.1 Electromagnetic compatibility and Radio spectrum Matters (ERM); Part 3: Specific conditions for Short-Range Devices (SRD) operating on frequencies between 9 kHz and 246 GHz
- EN 61000-4-2:2009 Electromagnetic compatibility (EMC); Part 4-2: Testing and measurement techniques – Electrostatic discharge immunity test;
- EN 61000-4-3:2006 Part 4-3: Testing and measurement techniques – Radiated, radio-frequency, electromagnetic field immunity test
- +A1:2008+A2:2010
- EN 300 220-2: V3.1.1 Short Range Devices (SRD) operating in the frequency range 25 MHz to 1 000 MHz; Part 2: Harmonised Standard covering the essential requirements of article 3.2 of the Directive 2014/53/EU for non-specific radio equipment
- EN 62479:2010 Assessment of the compliance of low power electronic and electrical equipment with the basic restrictions related to human exposure to electromagnetic fields (10 MHz to 300 GHz)